

2nd Layer of FEC in RAN for Mixed-Mode Broadcast / Multicast

August 29, 2018

Fasil Tesema, Volker Pauli

NOMOR Research GmbH, Munich, Germany

Summary

Evolution of broadcast / multicast verticals is pushing for a rapid growth of the wireless communication sectors to support the technical requirements. While 3GPP's discussion on broadcast / multicast for 5G-NR is at an early stage, the collaborative project 5G-XCast, under H2020 Phase II, is working towards providing a comprehensive solution for a future generation of broadcast / multicast embedded efficiently into 5G communication networks. This white paper presents a case study for the use of a 2nd layer of forward error correction (FEC) utilizing random linear network codes and feedback to implement highly efficient, reliable packet delivery for mixed-mode broadcast / multicast applications. The benefits over the state of the art schemes are illustrated by means of system-level simulations.

I Introduction

Rapid evolution of broadcast / multicast vertical sectors such as Multimedia and entertainment, automotive, public warning systems and internet of things, calls for the development of the broadcast / multicast communication technology to satisfy the requirements of these verticals.

5G-XCast is a H2020 Phase II project focused on broadcast and multicast communication enablers for the fifth generation (5G) of wireless systems, and it is working towards providing a comprehensive solution to support the requirements of the aforementioned vertical sectors. Among other things, the goals of the project include design of a highly flexible and efficient radio resource management for embedding broadcast / multicast into 3GPP's NR system, that is so far limited to unicast, i.e., the so-called "mixed mode" in contrast to pure "terrestrial broadcast" supporting also receive

only mode (ROM) devices. Nomor's focus in this project is on RAN protocols and radio resource management, which are being implemented in Nomor's system-level simulator for 5G mobile communication networks.

Diligent design and implementation of Radio Access Technology (RAT) protocols and the relevant radio resource management are very crucial to fulfill the requirements of new emerging technologies. After detailed survey performed by the 5G-XCast RAN working group, the major RAN protocol limitations of 3GPP's Rel 14 specification regarding broadcast / multicast have been highlighted in [1]. Among other things, the limitations on the radio resource management, latency and service scheduling have been identified. In regard to radio resource management, the current cellular broadcast / multicast systems provide limited support for feedback and higher layer RAN-level error correction schemes, leading to challenges in terms of providing the required spectral efficiency and packet loss rates.

For 5G-NR, 3GPP has specified a 1st layer of FEC in the physical layer: Low Density Parity Check (LDPC) code for data channels and polar codes for control channel [2]. These layer-1 error protection mecha-

nisms can be readily applied also in Broadcast/Multicast case. However, they are not sufficient for robustness at a larger time scale. But a 2nd layer of error protection is required to ensure adequate QoE. Hence, for LTE 3GPP has specified application layer FEC (AL-FEC) [3] as a 2nd layer of error protection based on Raptor codes. In designing broadcast / multicast for 5G, we now have the opportunity to reconsider the placement and design of this 2nd layer FEC mechanism.

Furthermore, 3GPP has considered application of HARQ feedback in the 1st layer of FEC [4]. However, it was found to not be very efficient as the number of users grows, the reason for this lying mainly in the fact that here different UEs in general ask for retransmissions of different packets due to mutually independent channel state variations.

We consider the use of a 2nd layer of Forward Error Correction (FEC) scheme in RAN as potential remedy to the identified challenges with respect to spectral efficiency and packet loss rates.

This white paper presents a detailed overview of the functions of RAN protocols in 5G-NR and a proposal to efficiently embed a 2nd layer of FEC within 5G-NR with consideration of the limitations of

putting the function at various layers in the protocol stack including an efficient feedback and dynamic redundancy adaptation strategy. Moreover, elaborated simulation results are presented showing the performance evaluation of the proposed scheme as compared to systematic AL-FEC codes used for LTE broadcast / multicast [3].

This paper is structured as follows. Section II presents state of the art RAN protocols. Section III presents a proposal for 2nd layer of FEC for Point-To-Multipoint (PTM) transmissions. Section IV demonstrates protocol implementation for 2nd layer of FEC. Section V shows details simulation results. Finally, Section VI presents concluding remarks.

II LTE RAN Protocols for PTM

II.A RAN Protocols in LTE-A PTM

The most relevant RRM-related protocol layers in LTE PTM [5], particularly for user plane data, are Radio Link Control (RLC), Medium Access Control (MAC) and Physical (PHY) layer, as depicted in Figure 1. Herein, the Packet Data Convergence Protocol (PDCP) is not used,

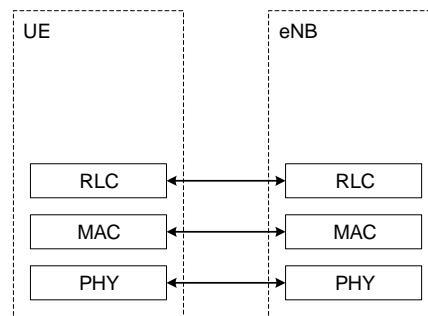

Figure 1: LTE RAN protocols for PTM data transmission [5].

i.e., operates in transparent mode. The major roles of the RLC layer are segmentation and/or concatenation of RLC Service Data Units (RLC SDUs) to fit into the available transport blocks provided by the lower layers. On the other hand, the major functions of the MAC protocol in LTE PTM are radio resource scheduling and multiplexing of data to lower layer transport blocks.

Figure 2 shows an example of user plane data flow in LTE PTM. First of all, the Multimedia Broadcast Multicast Service (MBMS) packets from higher layers are input to RLC layer as RLC SDUs. Based on the available MAC transport block, the RLC layer concatenates or segments RLC SDUs. Moreover, the RLC layer

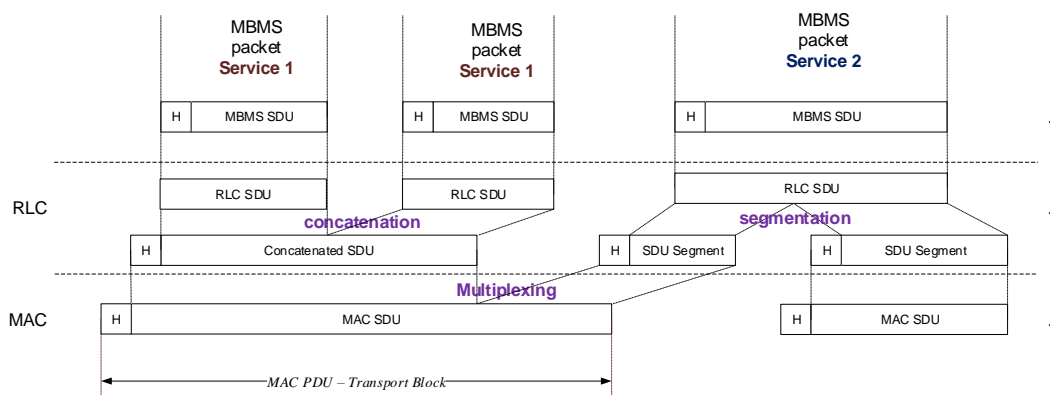

Figure 2: Packet flow for MBMS data [5].

appends header information to the RLC SDUs to generate RLC PDUs. The RLC header contains information that supports the corresponding receiver RLC to assemble RLC SDUs from received RLC PDUs. After RLC PDUs are generated, the MAC layer multiplexes RLC PDUs which may come from different sources, e.g. different MBMS services, into the available MAC transport block.

II.B NR RAN Protocols for Unicast

This section briefly outlines the radio protocols specified for NR with consideration of Point-to-Point (PTP) communication. Figure 3 illustrates the architec-

ture of the radio protocols pertinent to the communication between NR gNB and a UE. The specified radio protocols are Service Data Adaptation Protocol (SDAP), PDCP, RLC, MAC and PHY layers [6]. Here, the SDAP layer has been introduced which performs packet marking with QoS flow ID (QFI) and mapping of QFI to radio bearers.

The main functions of SDAP, PDCP, RLC and MAC in accordance with 3GPP's general description of NR [5] are listed below. Further details on the specification for layer 2 protocols (SDAP, PDCP, RLC and MAC) can be found in [7]-[10], respectively.

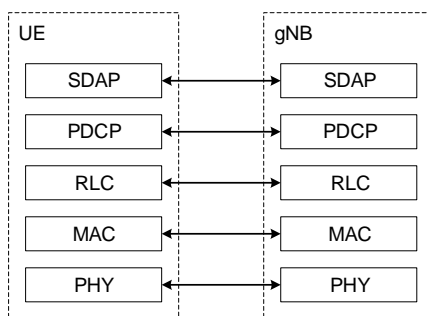

Figure 3: NR radio protocols for unicast data transmission [6].

SDAP Layer

- Mapping between a QoS flow and a data radio bearer
- Marking QoS flow ID (QFI) in both DL and UL packets

PDCP Layer

- Header compression and decompression: ROHC only
- Reordering and duplicate detection
- PDCP PDU routing (in case of split bearers)
- Retransmission of PDCP SDUs
- Ciphering, deciphering and integrity protection
- PDCP SDU discard
- PDCP re-establishment and data recovery for RLC AM

- Duplication of PDCP PDUs

RLC Layer

- Transparent Mode (TM) or Unacknowledged Mode (UM) or Acknowledged Mode (AM)
- Segmentation (AM and UM) and re-segmentation (AM only) of RLC SDUs
- Reassembly of SDU (AM and UM)
- RLC SDU discard (AM and UM)
- Error Correction through ARQ (AM only)
- Duplicate Detection (AM only)
- Protocol error detection (AM only)

MAC Layer

- Mapping between logical channels and transport channels
- Multiplexing / demultiplexing of MAC SDUs belonging to one or different logical channels into / from transport blocks (TB) delivered to / from the physical layer on transport channels
- Scheduling information reporting
- Error correction through HARQ
- Priority handling between logical channels of one UE
- Priority handling between UEs
- Packet re-ordering with re-transmissions with HARQ

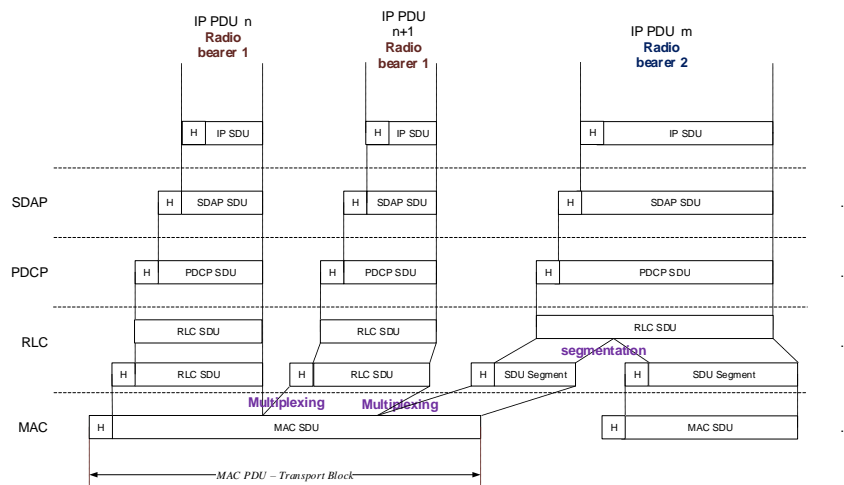

Figure 4: User plane data flow across 5G-NR radio protocols.

Figure 4 elaborates on an example of downlink user plane data flow across 5G-NR radio protocols. First of all, higher-layer IP packets are marked with QFI and mapped to radio bearers. Then, the PDCP layer performs header compression and security (ciphering and integrity protection) and forwards PDCP PDUs to the RLC layer. After that, the RLC layer wraps RLC SDUs or segments thereof into RLC PDUs based on the available MAC layer transport block size. Unlike current PTM systems which support only UM mode communication, the 5G-NR PTP can operate in UM or AM mode where

re-transmissions of lost packets can be performed via Automatic Repeat reQuest (ARQ) procedures. Following the RLC functions, the MAC layer multiplexes RLC PDUs which may come from the same or different sources, e.g. different radio bearers, into the available MAC transport block.

III 2nd Layer of FEC in RAN for PTM

In line with LTE PTM described in Section II, the proposed FEC scheme for PTM is discussed focusing on RLC and MAC func-

tions. The SDAP is assumed to have an one-to-one mapping between QFI and radio bearer IDs, and PDCP protocol functions are assumed to operate in transparent mode.

III.A Motivation

In the current LTE PTM specification HARQ feedback is not used. Proprietary implementation of dynamic link adaptation based on CQI feedback is possible for SC-PTM e.g. based on the worst UE in the cell. Based on these two restrictions a rather large margin has to be applied in selection of the modulation and coding scheme (MCS) leading to inefficient use of the radio resources. In fact, 3GPP performed a detailed study in [4] on PTM with group-based uplink feedback for link adaptation and HARQ. Moreover, the HARQ feedback messages are reported from each UE to the network whenever a packet is received. The number of CQI and HARQ ACK/NACK messages scale with the number of UEs, leading to a high feedback load in scenarios with high number of users where PTM is typically a suitable option. Even more importantly, the HARQ-based scheme of [4] becomes very inefficient as the number of UEs grows as packet loss events at differ-

ent UEs are largely statistically independent such that different UEs will typically ask for retransmissions of different packets.

The work in [11] proposed exclusion of the HARQ ACK/NACK feedback and use of only CQI feedback to achieve an improved performance via enhanced outer loop link adaptation techniques, but by construction lacks the capability to deliver data with high spectral efficiency with very high reliability, as there are no means to reliably fix packet losses e.g. due to channel variations not predicted by the CQI reports. Hence, an alternative error correction scheme with minimal overhead of feedback messages that at the same time provides high reliability is desirable.

Accordingly, herein an alternative technique that can provide the required performance via forward error correction schemes is proposed. It is based on Random Linear Network Coding (RLNC) which is selected due to its suitability for radio channels that induce packet losses [12], and the flexibility of decoding with or without packet re-ordering as long as the required number of network coding PDUs is available at the receiver. Unlike block codes such as Raptor codes [3], RLNC offers the capability to perform

successive en- / decoding and recoding [13].¹ The entailed feature of recoding makes RLNC interesting option to scale it to co-operative / D2D-assisted broadcasting, which is however beyond the scope of this paper.

III.B Basics of RLNC

RLNC can be used to reliably transmit data streams in an end-to-end manner over a channel that induces packet losses. It incorporates 3 major functions: encoding, decoding and recoding.

III.B.1 Encoding

The encoding process consists of forming Network Coding (NC) PDUs $\mathbf{p}_{nc,n}$ from linear combinations of NC Service Data Units (SDUs) $\mathbf{s}_{nc,m}$ to be transmitted. The coefficients $c_{n,m}$ for these linear combinations are selected randomly from a finite field, e.g. of size 256. They are transmitted as side information along with the PDUs as the decoder needs them in its

¹We note, however, that the 2nd layer FEC scheme presented herein could almost just as well be implemented based on any other Fountain coding scheme, including Raptor or RaptorQ codes as specified by 3GPP for AL-FEC in LTE eMBMS.

decoding process.² This encoding process is illustrated in the following equation:

$$\mathbf{p}_{nc,n} = \sum_{\forall m} c_{n,m} \mathbf{s}_{nc,m}. \quad (1)$$

When stacking multiple NC-PDUs as rows into a matrix, we obtain the following description for a “generation” $\{\mathbf{s}_{nc,m} | 1 \leq m \leq N_G\}$ of a finite size N_G :

$$\underbrace{\begin{bmatrix} \mathbf{p}_{nc,1} \\ \mathbf{p}_{nc,2} \\ \vdots \end{bmatrix}}_{\triangleq \mathbf{P}} = \underbrace{\begin{bmatrix} c_{1,1} & \dots & c_{1,N_G} \\ c_{2,1} & \dots & \vdots \\ \vdots & \dots & \vdots \end{bmatrix}}_{\triangleq \mathbf{C}} \cdot \underbrace{\begin{bmatrix} \mathbf{s}_{nc,1} \\ \mathbf{s}_{nc,2} \\ \vdots \\ \mathbf{s}_{nc,N_G} \end{bmatrix}}_{\triangleq \mathbf{S}} \quad (2)$$

where with every PDU a row is added to the matrix \mathbf{C} . Strictly speaking the organization of SDUs in disjoint sets a.k.a. generations is not required, however it is expedient for the purpose keeping track of the decoding progress.

III.B.2 Decoding

Having discussed the encoding process, one can see that the decoding process can basically be implemented by inverting

²Expediently, this transfer is done by sending only a seed to a certain random number generator that generates these coefficients, cf. e.g. [14].

the matrix C , while this may of course not be the computationally most efficient approach. It is then also easy to understand that this is possible only if the rank of C is equal to the number of encoded SDUs. Hence, a necessary (but not sufficient) condition for successful decoding is that at least as many PDUs have been received as SDUs are encoded in the set of PDUs. Based on the fact that the encoding coefficients $c_{n,m}$ are randomly drawn, the probability that the above-mentioned rank-criterion is also sufficient is close to 1 if C is properly populated with non-zero encoding coefficients. For a detailed analysis see Figure 10. The main advantage of this concept is that it hardly matters to the decoder, which of the PDUs it receives and which ones get lost along the way, or which ones are received first in a multi-path scenario. As soon as it has received a sufficient number of PDUs, which rarely has to be larger than the number of encoded SDUs, it can decode the SDUs. As such, the scheme is very efficient in terms of overhead for protection against packet loss. The difficulty is to determine an adequate number of PDUs that need to be transmitted over a lossy link.

III.B.3 Recoding

One of the main distinguishing features of RLNC is the option to do recoding in entities that have received some RLNC PDUs. This could be either one of several cooperating UEs or a relay node that received PDUs on different routes in a multi-route system. However, co-operative communication is not within the scope of this document.

IV Protocol Function Implementation for 2nd Layer of FEC via RLNC

This section demonstrates the feasible options of implementation of RLNC functions inside the radio protocol stack for PTM communication.

IV.A Feasible location for NC Sub-layer

The viable candidate locations to install NC sublayer function are demonstrated in Figure 5. With RLNC, one of the necessary requirements for decoding is that received RLNC PDUs have fixed size (which is a design parameter). In other words, reception of variable length RLNC PDUs

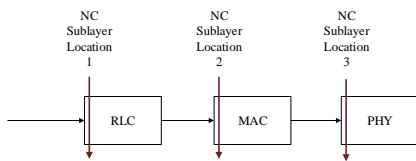

Figure 5: The viable candidate locations to install NC sublayer function.

from the same generation sequence is not suitable for decoding. As such, NC sublayer location #1 is flexible enough to perform RLNC en- / decoding under the constraint of fixed RLNC PDU size. On the other hand, NC sublayer location 2 and 3 are not feasible candidates as both options don't guarantee forwarding of fixed RLNC PDU sizes to their respective lower layers, as described in the following subsections. Figure 6 demonstrates the limitation of installing NC sublayer functions at the entry of MAC sublayer in the radio access. Herein, RLC PDUs will be inputs to the NC sublayer function. The generated RLNC PDUs will have fixed size equal to the maximum of RLC PDUs plus NC header information, as shown by the blue boxes in the figure. However, the RLNC PDUs will in general not be able to fit into the transport block provided by the lower layers.

Figure 7 demonstrates the potential limi-

tations if NC sublayer function is installed as one of the physical layer procedures.

As described in [2], 5G-NR physical layer has a set of procedures that perform 1st layer of FEC to provide bit-level robustness of transmitted data against lossy channel conditions. Herein, the major procedures of the specified error correction scheme are segmentation of a transport block into equally sized code blocks of a given maximum size, Cyclic Redundancy Check (CRC) for decoding failure detection in each code block, and use of Low Density Parity Check (LDPC) codes for error correction on data channels.

The potential location for a 2nd layer of FEC in this case is after segmentation of the transport block into code blocks. Generally, the 2nd layer of FEC packets should be distributed across different transport blocks to provide more robustness against fading processes. However, based on the characteristic of equally sized RLNC PDUs across an entire generation the generated RLNC PDUs would in general not fit into the allocated physical transmission resources, unless the amount of resources allocated to every transmission is selected such that it can without significant padding carry an integer number of complete RLNC PDUs.

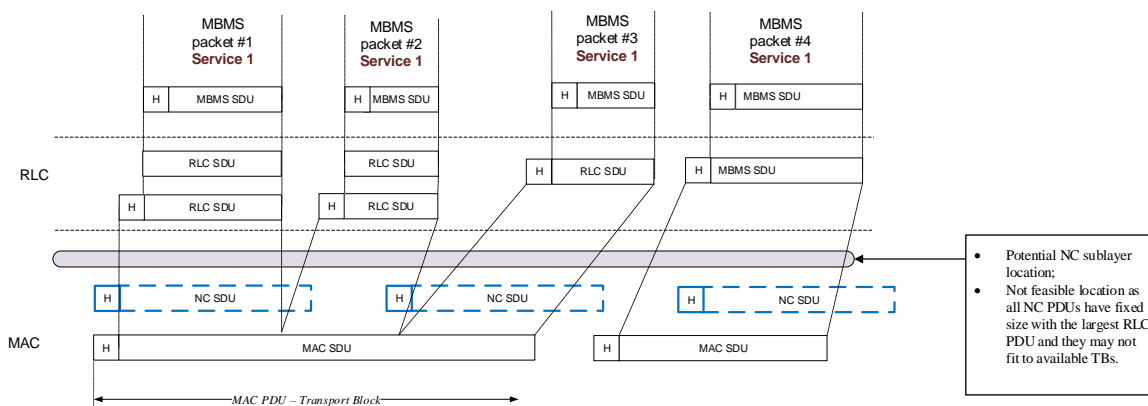

Figure 6: Potential limitations if NC sublayer function is installed in MAC layer.

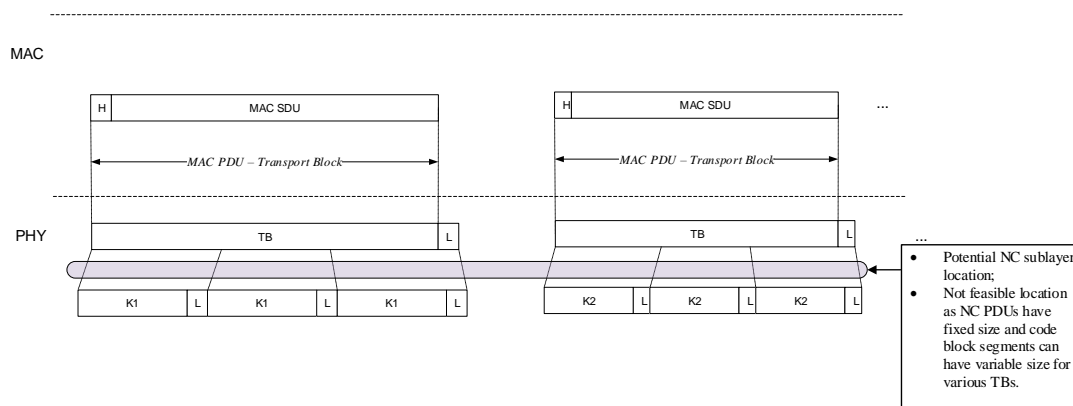

Figure 7: Potential limitations if NC sublayer function is installed in physical layer.

IV.B Options of NC Sublayer

Assuming the feasible NC sublayer location #1, two major options of NC sublayer functions are investigated as follows.

Figure 8 shows the first feasible option to perform RLNC functions inside the radio protocol at NC sublayer location #1. Herein, MBMS packets which in general have variable sizes are received at the NC sublayer as NC SDUs. Then, the RLNC encoder generates at least as many fixed size RLNC PDUs as the number of input NC SDUs. In this case, the size of an RLNC PDU is the maximum of sizes of the encoded NC SDUs, which directly constitutes a disadvantage of this approach. The major advantage of this option is that it allows instantaneous encoding based on the available NC SDUs.

Figure 9 describes the second feasible option to perform RLNC functions inside the radio protocol at NC sublayer location #1. In this case, a fixed SDU size is configured with the same size as the fixed size RLNC PDU payload. As a result, MBMS packets from the higher layers are segmented and / or concatenated to fit into the fixed-size NC SDU, e.g. see packet #2, #3, and #4 in the NC SDUs shown in Figure 9. Then the NC SDUs are encoded by the RLNC encoder to generate RLNC PDUs.

The main drawback of this option is the fact that NC SDU sizes are fixed and needs to be filled with complete or segments of incoming packets. If an NC SDU is only partially filled, it waits for incoming packet before it is passed on to the encoder. In essence, it may incur delays in the process. However, a minimum affordable delay can be configured to stop waiting for incoming packet and use padding instead.

Due to its efficient radio resource utilization capability, we select option #2 (cf. Figure 9) as a way forward in the implementation of RLNC-based 2nd layer of FEC in RAN for PTM communication.

IV.C Proposed Implementation

As described in Section III.B.2, the main requirement for a UE to decode RLNC encoded data is to receive at least as many RLNC PDUs as the number of encoded NC SDUs. However, some RLNC PDUs can be lost due to lossy wireless transmission channel. Hence, a certain number of extra RLNC PDUs will have to be sent to the UE to compensate for the loss of packets. Existing approaches like the AL-FEC standardized for LTE do this only in a pre-emptive manner, which may more

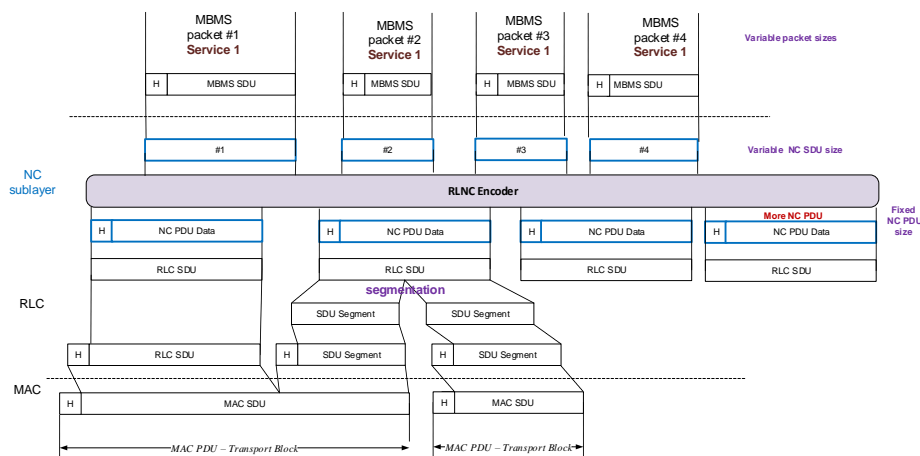

Figure 8: 1st feasible option for RLNC functions placement above RLC layer (location #1).

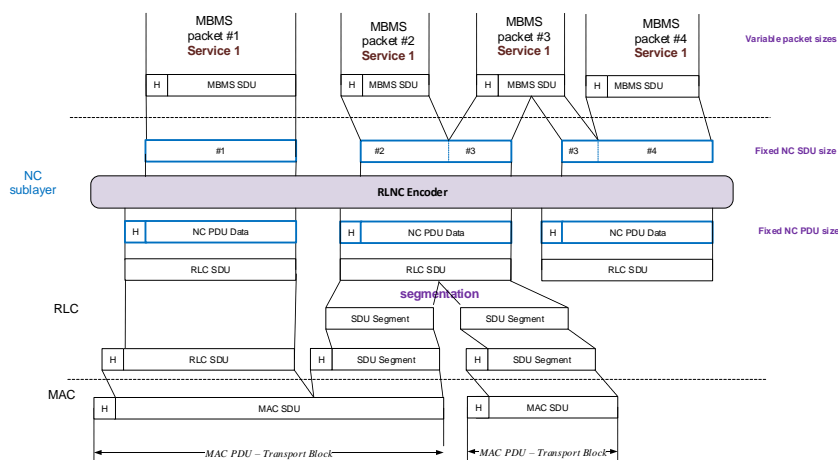

Figure 9: 2nd feasible option for RLNC functions placement above RLC layer (location #1).

than needed in some situations and still not be sufficient in others. Hence the proposal of this work is to use feedback for the UEs to signal how many more PDUs would be required.

While [15] proposes the use of sliding window to optimize the en- / decoding complexity in the application layer, we herein stick to the use of a sequence of generations of fixed size successive en- / decoding in order to maintain en- / decoder history without incurring delays related to block-wise encoding. If the UE is unable to decode all NC SDUs of a certain generation after reception of a given number of RLNC PDUs, it can use uplink feedback to signal to the network the number of RLNC PDUs required for that generation. Then, the network transmits additional RLNC PDUs from the notified generation, doing so again over the multicast / broadcast channel, which is a clear improvement over the conventional packet-specific HARQ considered in [4]. Unlike HARQ ACK / NACK feedback messages that are triggered with every reception of a packet, the NC uplink feedback is triggered only if the UE is unable to decode after reception of RLNC PDUs that are outputs of a successive encoding of SDUs from a certain generation sequence. For efficiency this checking and reporting

can be restricted to be performed only with a certain periodicity depending on the latency requirements of the service, e.g. 50ms.

In this process, the network can take into account already transmitted additional PDUs if multiple RLNC feedback messages have been received from different UEs for the same generation, as additional PDUs requested by one UE are again multicasted / broadcasted and may hence also be received by other UEs. One aspect of such an implementation is that the network tracks the count of transmitted PDUs for the last N generation. Ideally, the network would track all previous generation; however, it is expensive in terms of memory requirements to maintain the entire history, and may also not be required depending on latency requirements of the service. Hence, maintaining the count of additionally sent PDUs for the last N generations, which is a design parameter, is indispensable. Great care must be taken with the computation of how many additional PDUs are required in order to provide the truly required number without on the other hand overloading the transmit buffer with an exorbitant number of additional PDUs.

V Performance Evaluation

V.A Simulation Settings

System-level simulations of communication networks mimic geographically confined parts of a communication network consisting of multiple base stations and numerous UEs, gateways, application servers etc., i.e., including layer-2/3 and possibly higher layer protocol functionalities. This allows for evaluation of aspects such as resource management, interference between different concurrent transmissions or higher-layer consideration, such as the impact of radio network performance on TCP connections or user experience at the application level. This may take into account UE distributions or mobility according to synthetic models or in “real-world” scenarios.

Herein, we compare the newly proposed feedback-based 2nd layer FEC scheme against two reference schemes:

No AL-FEC: Operation without any kind of AL-FEC and

AL-FEC: Operation with LTE-like AL-FEC, i.e., a systematic fountain code. Deviating from the LTE specification, we use a systematic RLNC code with optimal—e.g.

Parameter	Value
Carrier frequency	3.5 GHz
Total BS transmit power	51 dBm
Systembandwidth	100 MHz
Number of BS antennas	8
Inter-site distance	200 m
Number of UE antennas	8
UE mobility model	3kmph, randomly uniform distr.
BS noise figure	5 dB
UE noise figure	9 dB
BS ant. element gain	14 dBi
BS ant. elev. 3dB-BW	10°
BS ant. azim. 3dB-BW	65°
BS ant. mech. downtilt	20°
UE ant. element gain	0 dBi
PTP traffic model	Full buffer
PTM traffic model	8Mbps, packet arrival rate 100Hz
Channel model	3GPP TR 38.901 [16]

Table 1: Main simulation parameters.

Gauss-Jordan elimination based—decoding.

Of the various test environments defined for IMT-2020 evaluations [17], urban dense test environment is used for sample performance evaluation of the proposed 2nd layer of FEC in RAN and its comparison with AL-FEC and no AL-FEC. Table 1 summarizes the main simulation parameters, which are derived from the “Dense Urban” scenario. The 2nd layer FEC mechanisms all operate in the GF(256) and with a generation size of 100 symbols, i.e., over 1sec.

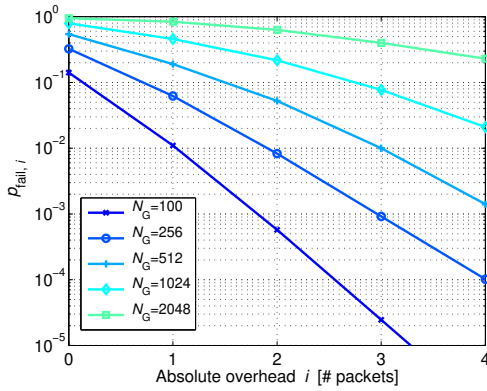

Figure 10: Decoding performance of systematic RLNC over erasure channel with 40% packet loss rate.

V.B Simulation Results

We start by analysing the decoding efficiency of the systematic RLNC code used in this paper. To this end, we consider the probability of failure as a function of the reception overhead, i.e., the number of PDUs received in excess of the theoretical absolute minimum required for decoding a generation, cf. Figure 10. We assume a 40% packet loss rate in the simulation, packet losses being randomly and uniformly distributed over all sent packets. While the overhead in terms of absolute number of additional packets required to be sent to bring down the probability of decoding failure grows with the genera-

tion size, the relative overhead computed via

$$-1 + \sum_{i=0}^{\infty} \frac{N_G + i}{N_G} (1 - p_{\text{fail},i}) \cdot \prod_{j=0}^{i-1} p_{\text{fail},j} \quad (3)$$

decreases slightly with the generation size. At this $p_{\text{fail},i}$ denotes the probability that the decoder cannot completely decode a generation with reception overhead i , as shown in Figure 10. We find that even at $N_G = 100$ the relative overhead is already down to 0.14%, which is already quite negligible and justifies our selection of $N_G = 100$ in the interest of reduced decoding complexity.

Figures 11, 12 and 13 show the cumulative distribution function (CDF) of application layer spectral efficiency, application layer packet loss rate and RLC SDU loss rate, respectively, for AL-FEC with 10% redundancy at application layer and different MCSs at layer-1 FEC as well as no AL-FEC for one sample MCS. Here, the CDFs of the spectral efficiency are simple step functions due to the fixed modulation and coding parameters. With more aggressive MCS settings, i.e., higher spectral efficiency of the layer-1 transmission scheme, both the application layer packet loss rate and the RLC SDU loss rate in-

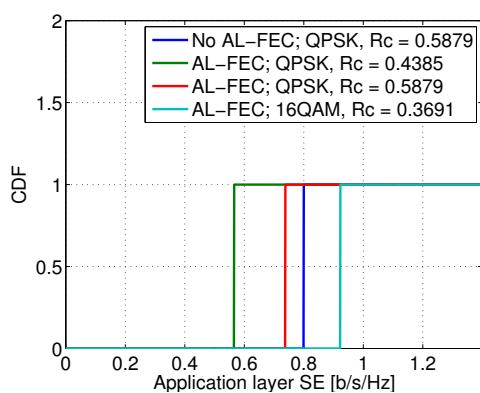

Figure 11: CDF of application layer SE [b/s/Hz] for no AL-FEC and AL-FEC with various MCS settings.

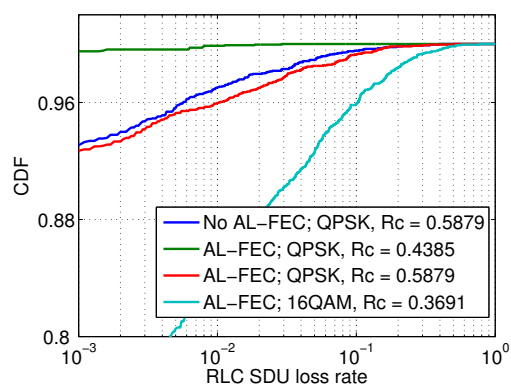

Figure 13: CDF of RLC SDU loss rate for no AL-FEC and AL-FEC with various MCS settings.

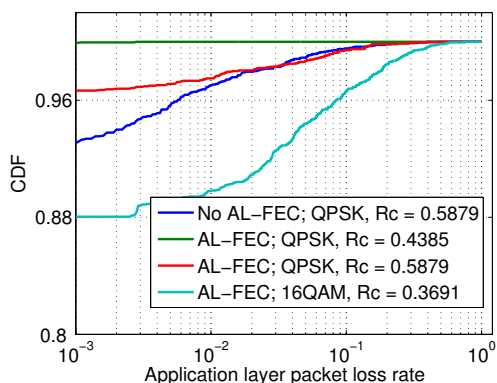

Figure 12: CDF of application layer packet loss rate for no AL-FEC and AL-FEC with various MCS settings.

crease. Comparing AL-FEC with no AL-FEC for the same MCS, one can observe that as expected there is no impact at the RLC layer in terms of the RLC SDU loss rate. However, at the application layer, AL-FEC provides improved (lower) packet loss rate, as it is able to repair smaller packet loss events.

Figures 14 and 15 show the CDF of application layer spectral efficiencies and packet loss rates, respectively, for no AL-FEC and AL-FEC with the same MCS setting of 'QPSK, Rc = 0.59' for various levels of redundancy of repair packet: 10%, 20% and 30%. Herein, AL-FEC considerably improves the application layer packet

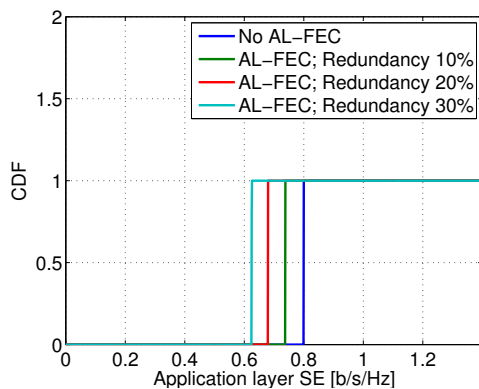

Figure 14: CDF of application layer SE [b/s/Hz] for no AL-FEC and AL-FEC with various redundancy levels and 'QPSK, $R_c = 0.59$ '.

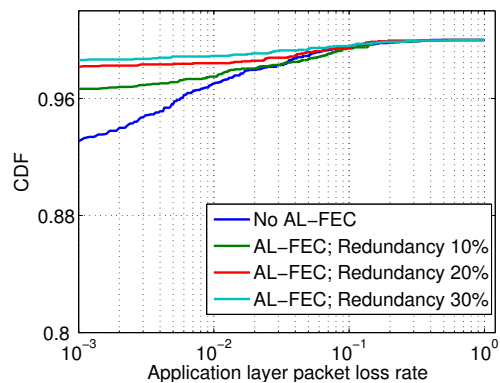

Figure 15: CDF of application layer packet loss rate for no AL-FEC and AL-FEC with various levels of redundancy 'QPSK, $R_c = 0.59$ '.

loss rate at a cost of reduced spectral efficiency. It can be observed, how higher levels of redundancy are able to fix higher packet loss rates in the lower layers.

Figures 16 and 17 show CDF comparison of 2nd layer of FEC in RAN against AL-FEC and no AL-FEC in terms of application layer spectral efficiencies and packet loss rates, respectively, for a sample MCS setting of 'QPSK, $R_c = 0.59$ '. The 2nd layer of FEC in RAN utilizes periodic feedback (50ms) for triggering transmission of appropriate numbers of additional RLNC PDUs to compensate for lost packets. Consequently, the 2nd layer of FEC

in RAN exhibits further improved packet loss rate performance as compared to conventional AL-FEC. At the same time, the spectral efficiency for 2nd layer of FEC in RAN is higher than that of AL-FEC because in the 2nd layer of FEC additional RLNC PDUs are not sent preemptively but are generated and sent only based on request. Accordingly, with the current configuration, in approximately 60% of all drops no additional RLNC PDUs are required for decoding and in less than 10% of all drops, the overall spectral efficiency is lower than that of conventional AL-FEC, but with the benefit of having zero (at least $< 10^{-3}$) packet loss rate.

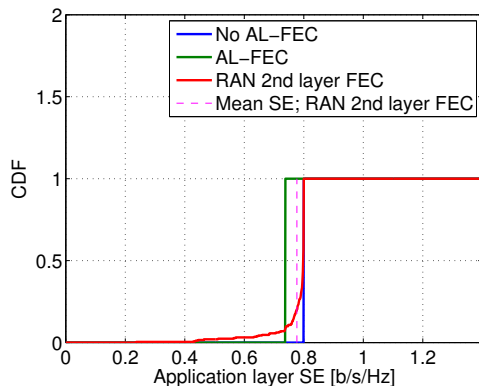

Figure 16: CDF of application layer SE [b/s/Hz] for no AL-FEC, AL-FEC and 2nd level of FEC in RAN with 'QPSK, $R_c = 0.59$ '.

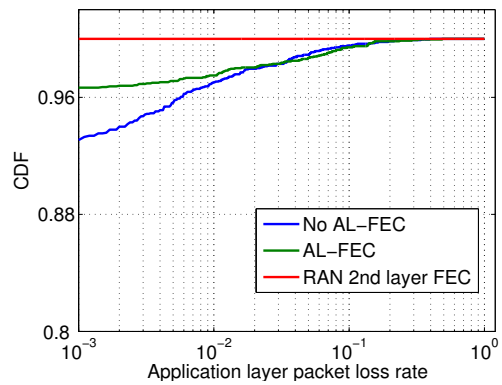

Figure 17: CDF of application layer packet loss rate for no AL-FEC, AL-FEC and 2nd level of FEC in RAN with 'QPSK, $R_c = 0.59$ '.

Figures 18, 19 and 20 show the delay analysis of 2nd layer of FEC in RAN as compared to AL-FEC. Figure 18 contains the inverse-CDF (I-CDF) of the difference between the reception time of an application layer packet and its transmission time for AL-FEC with various MCS settings and for 2nd layer of FEC with 'QPSK, $R_c = 0.59$ '. For AL-FEC, the application layer delay is higher for less conservative MCS settings since the packet loss rate is higher and some application layer packet are recovered after reception of repair packets and others are delayed by the thus triggered reordering process. Note that for the conventional AL-FEC, no delays beyond 1.1s occur, as the reordering in the

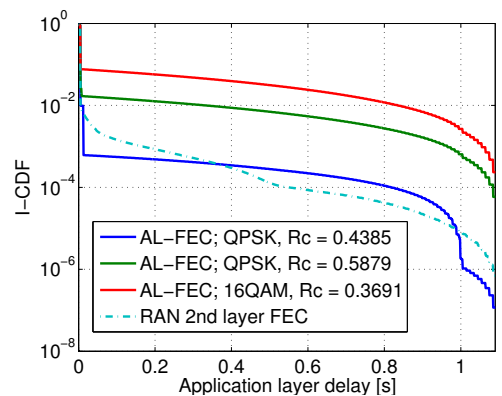

Figure 18: I-CDF of application layer packet delay for AL-FEC with various MCS settings and for 2nd layer of FEC with 'QPSK, $R_c = 0.59$ '.

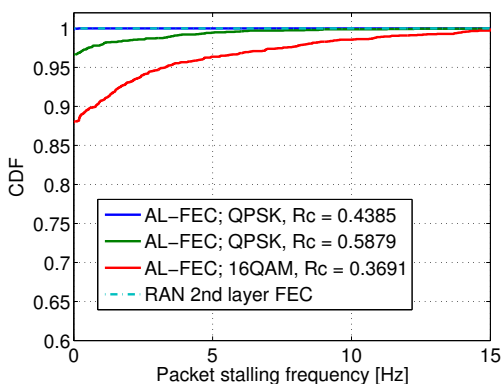

Figure 19: CDF of application layer packet stalling frequency for AL-FEC with various MCS settings and for 2nd layer of FEC with 'QPSK, $R_c = 0.59$ '.

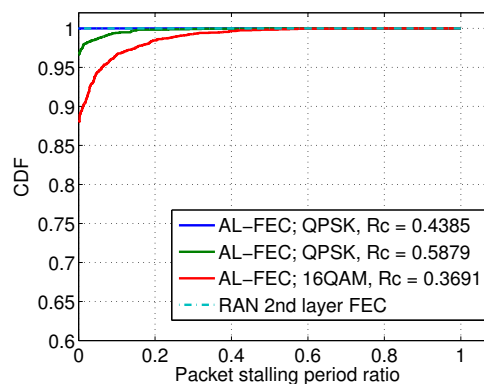

Figure 20: CDF of application layer packet stalling period ratio for AL-FEC with various MCS settings and for 2nd layer of FEC with 'QPSK, $R_c = 0.59$ '.

receiver is implemented to assume that 1.1s after the reception of the first PDU of a generation no more PDUs from that generation will be received.³

The application layer delay distribution is considerably more favorable for the 2nd layer of FEC as compared to AL-FEC for the same MCS setting of 'QPSK, $R_c = 0.59$ ' due to the fact that repair packets are re-transmitted on the fly based on the periodic opportunity for feedback.

Such application layer delay can be crucial in determining the quality of experi-

³Recall that each generation contains SDUs generated over an interval of 1sec.

ence in watching a video, where a play-out buffer is installed to avoid frequent stalling of playback while in normal operation incurring some buffering delay. In order to achieve a high quality of experience the target is to minimize this buffering delay, while keeping the frequency of stalling events and the total relative time of stalls, i.e., the aggregated stalling time normalized by the observation window length, low. Figures 19 and 20 show the CDFs of packet stalling frequency and relative packet stalling period, respectively, assuming a play-out buffer size / stalling threshold of 1.1s, i.e., slightly larger than what is covered by one generation of NC

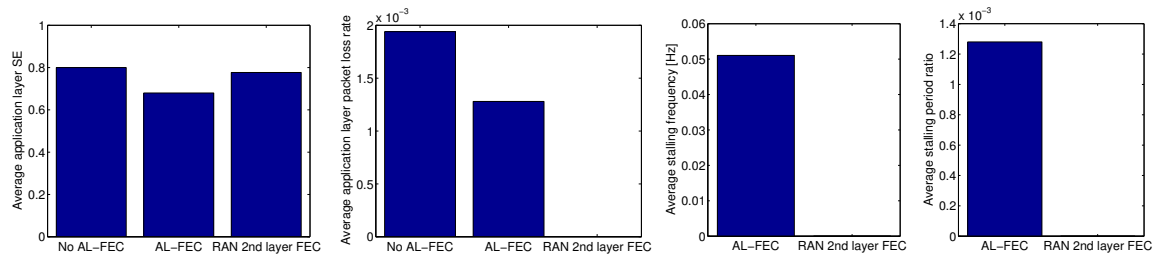

Figure 21: Comparison among no AL-FEC, AL-FEC and 2nd layer of FEC in RAN.

SDUs to allow the repair packets of the systematic AL-FEC code sent at the end of the generation to repair also losses on all packets of the generation.

In this case, the 2nd layer of FEC provides a better performance in terms of packet stalling frequency and packet stalling period as compared to AL-FEC for the compared sample MCS setting of 'QPSK, Rc = 0.59'. Furthermore, it can be observed that it exhibits delay characteristics very similar to those of conventional AL-FEC with 'QPSK, Rc = 0.44', while the overall spectral efficiency is about 30% higher compared to this reference scheme. Judging from Figure 18 one can also observe that with the new scheme the play-out buffer time could be reduced to 0.2s while the probability of stalling due to a late packet would still be below 10^{-3} , i.e., once in every 10s, or once in every 100s with a play-out buffer of 0.5s.

VI Conclusions

A highly flexible and efficient radio access technology is one of the requirements to support future generation broadcast / multicast vertical sectors. One of the limitations of current radio systems is inefficiencies in spectral efficiency and packet loss rates due to shorter and longer time scale degradation of the signal. In 3GPP a first layer of FEC on the physical layer is specified mainly for robustness against shorter time scale degradation of radio signals, while for broadcast / multicast systematic Raptor codes are applied to recover losses left after physical-layer FEC. This white paper proposed a feedback-based 2nd layer of FEC scheme for mixed mode broadcast / multicast to implement highly efficient wireless broadcast / multicast system that can provide robustness for longer time scale signal degradations, as well.

Elaborate system level analysis were performed to assess the performance of this scheme in comparison to state of the art reference schemes, namely conventional systematic AL-FEC codes and operation without AL-FEC. Figure 21 summarizes the major findings of this system-level simulation based study in terms of average application layer spectral efficiency, average packet loss rate, average stalling frequency and average stalling period ratio. The analysis was done with the latest channel models used for IMT-2020 evaluation and within 3GPP, in particular the “dense urban” scenario. It was found that by sacrificing some overall spectral efficiency the AL-FEC provides an improvement in the packet loss rate by around 35%, as compared to no AL-FEC. On the other hand, the 2nd layer of FEC as proposed in this paper avoids packet losses practically entirely, with limited sacrifice on average overall spectral efficiency (around 3%), because transmissions of additional repair packets are triggered only with loss of packet, i.e., no regular redundant repair packets are needed. In regards to comparison of 2nd layer of FEC in RAN and AL-FEC in terms of average stalling frequency and average stalling period ratio for video streaming application, we observed that these can be

avoided practically entirely, while the new scheme still operates at a higher average spectral efficiency.

Acknowledgement: This work was supported in part by the European Commission under the 5G-PPP project Broadcast and Multicast Communication Enablers for the Fifth-Generation of Wireless Systems 5G-XCast (H2020-ICT-2016-2 call, grant number 761498). The views expressed in this contribution are those of the authors and do not necessarily represent the project.

References

- [1] D. Vargas and D. Mi (Eds). Performance of LTE Advanced Pro (Rel-14) eMBMS, deliverable D3.1, 5G-PPP 5G-Xcast project. November 2017.
- [2] 3GPP. NR; NR and NG-RAN Overall Description; Stage 2 (Release 15). 3GPP TS 38.212 v15.2.0, June 2018.
- [3] 3GPP. Multimedia Broadcast / Multicast Service (MBMS); Protocols and Codecs (Release 15). 3GPP TS 26.346 v15.1.0, June 2018.
- [4] 3GPP. E-UTRA; Study on Single-Cell Point-to-Multipoint Transmis-

- sion for E-UTRA (Release 13). 3GPP TR 36.890, July 2015.
- [5] 3GPP. Technical Specification Group Radio Access Network; Evolved Universal Terrestrial Radio Access (E-UTRA); E-UTRAN; Overall description; Stage 2 (Rel. 14). 3GPP TS 36.300 v14.6.0, April 2018.
- [6] 3GPP. NR; Multiplexing and Channel Coding (Release 15). 3GPP TS 38.300 v15.2.0, June 2018.
- [7] 3GPP. E-UTRA and NR; Service Data Adaptation Protocol (SDAP) Specification (Release 15). 3GPP TS 37.324 v15.0.0, June 2018.
- [8] 3GPP. NR; Packet Data Convergence Protocol (PDCP) Specifications (Release 15). 3GPP TS 38.323 v15.2.0, June 2018.
- [9] 3GPP. NR; Radio Link Control (RLC) Protocol Specifications (Release 15). 3GPP TS 38.322 v15.2.0, June 2018.
- [10] 3GPP. NR; Medium Access Control (MAC) Protocol Specifications (Release 15). 3GPP TS 38.321 v15.2.0, June 2018.
- [11] A. Awada, D. Navrátil, and M. Säily. Study on Single-Cell Point-to-Multipoint Transmission for Public Safety Communications with eMBMS LTE Networks. In *IEEE WCNC*, April 2016.
- [12] T. Ho, M. Médard, R. Koetter, D.R. Karger, M. Effros, J. Shi, and B. Leong. A Random Linear Network Coding Approach to Multicast. *IEEE Transactions on Information Theory*, Oct 2006.
- [13] M. Toemoeskoezi, F. Fitzek, D. Luciani, M. Pederson, and P. Seeling. On the Delay Characteristics for Point-to-Point Links using Random Linear Network Coding with on-the-fly Coding Capabilities. In *IEEE European Wireless Conference*, May 2014.
- [14] V. Roca and B. Teibi. Sliding Window Random Linear Code (RLC) Forward Erasure Correction (FEC) Schemes for FECFRAME. IETF Draft, March 2018.
- [15] V. Roca, T. Tran, B. Teibi, C. Burdiant, and C. Thienot. Less Latency and better Protection with AL-FEC Sliding Window Codes: A robust Multimedia CBR Broadcast Case Study. In *IEEE WiMob*, October 2017.

- [16] 3GPP. Technical Specification Group Radio Access Network; Study on Channel Model for Frequencies from 0.5 to 100 GHz (Rel. 14). 3GPP TR 38.901 v14.1.1, July 2017.
- [17] ITU. Guidelines for Evaluation of Radio Interface Technologies for IMT-2020. ITU Document 5/57-E, October 2017.

Note:

This white paper is provided to you by Nomor Research GmbH. Similar documents can be obtained from <http://www.nomor.de>. Please support our work in the social media.

Consultancy Services: Please contact us in case you are interested in our services by sending an email to info@nomor.de.

3GPP related Consultancy Services:

- Link and System Level Simulations
- Research, Analyses and Concept Development
- Demonstration and Prototyping
- 3GPP Standardization Support
- Technology Training
- Patents Support

Technical Areas:

- Mobile Communication Networks
- Mission Critical Communication
- Vehicular Communication
- Satellite and Broadcast
- Multimedia Delivery and Content Distribution
- Internet of Things

Disclaimer:

This paper is provided for informational purpose only. We do not accept any responsibility for the content of this newsletter. Nomor Research GmbH has no obligation to update, modify or amend or to otherwise notify the reader thereof in the event that any matter stated herein, or any opinion, projection, forecast or estimate set forth herein, changes or subsequently becomes inaccurate. Please note in our assessment(s) we only considered those facts known to us and therefore the results of our assessment / assessments are subject to to change due to facts currently not known to us. Furthermore, please note, with respect to our assessment(s) different opinions might be expressed in the relevant literature and there may be some other interpretations which are scientifically valid.