

# Relay Enhanced LTE-Advanced Networks – Resource Allocation and QoS provisioning

Thiago M. de Moraes, Muhammad Danish Nisar,  
Eiko Seidel,  
NOMOR Research GmbH, Munich, Germany  
July, 2012

## Summary

Some of the key driving forces behind the transition from the UMTS based cellular system to the Long Term Evolution Advanced (LTE-A) are to improve the mean and the cell-edge throughput, improve the user fairness, and improve the quality of service (QoS) satisfaction for all users. In the latter system, relays appear as one of the most prominent enabler for improving the cell-edge user experience while increasing the system's fairness.

In this white paper, we present the basics of relay deployments in LTE-A networks. Moreover, we analyze resource allocation problem for Relay Nodes (RN) deployments and present some of the solutions for improvement in system resource usage and QoS satisfaction. Afterwards, we introduce the capabilities of NOMOR's LTE-A system level simulator and evaluate the performance of LTE-A relay systems under the described solutions.

## Introduction & Motivation

During the past few years mobile operators have experienced an increase in the data rate demand mainly due to the popularization of the smartphones and their data hungry applications. In order to maintain the competitiveness of their

system and to be able to support high data rate demands, the 3<sup>rd</sup> Generation Partnership project (3GPP) has proposed LTE as a possible candidate technology for future mobile networks. However, as the achieved rate was still under the ITU requirement for the 4<sup>th</sup> generation of mobile services [1][2], new features were added to develop the so called LTE Advanced standard.

Advanced relaying is one of the most prominent features in LTE-A systems, targeting at improvement of the cell-edge user performance and fairness among users. Relays, in LTE-A, are designed to be low cost and lower power nodes which can be easily and quickly deployed when needed. In its release 10, LTE-A has standardized the use of the so-called type-1 relays which are non-transparent relays: when the RN is active it is seen by the eNB as a User Equipment (UE), whereas the UEs close to the RN coverage see it as a regular eNB, i.e., the RN terminates all the layer-2 and layer-3 radio interfaces. Therefore, the relay is supposed to maintain its own physical cell id and to broadcast all control and reference signalling to the subordinate UEs. Moreover, the scheduling for the Relay-attached UE (R-UEs) is done in the RN, independently of the eNB scheduler.

The most challenging feature in a Relay Enhanced Network (REN) is the management of wireless backhaul link. Differently from a regular eNB and from other access technologies, the relay node does not have a wired connection to the EPC, or the core network. In this case wireless backhaul link is established between the RN and the eNB during the RN connection

phase. From this moment onwards, the latter acts as a proxy server towards the core network and is called Donor eNB (DeNB) due to the fact that this one donates its radio resources to the RN's backhaul link. According to the way that the wireless backhaul link is allocated, the RNs can be classified as:

- In-band, when the backhaul link is allocated on the same carriers as the access link
- Out-band, when the backhaul link and the access link are allocated on different carries.

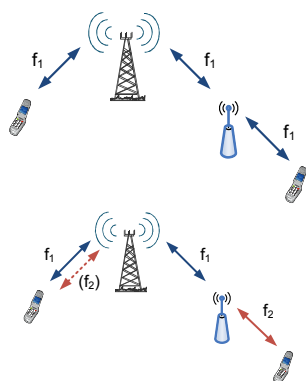

Figure 1: In-band (top) and out-band (bottom) modes of relay operation

For in-band relays, as both access and the backhaul links use the same carrier further constraints have to be imposed to avoid self interference on the relay antennas. In LTE-A, the links are time multiplexed with the help of MBSFN sub-frames. These are special sub-frames initially introduced for multimedia broadcasting during which the UEs will only receive if they are engaged in the broadcast service. In an enhanced relay scenario, they are used to inform the subordinate UEs of a RN that no transmission is expected in the downlink during that sub-frame. In this case, UE would automatically turn off the receiver to save battery. The uplink case is easier, since the RN may choose not to schedule any data from UEs for the sub-frames during which it will transmit to the DeNB. However, it is important to note

that according to the standard, it is not possible to use MBSFN sub-frames at certain locations in the frame structure, since there are broadcast messages, synchronization signals, and information blocks that the UE has to receive. Therefore some sub-frames cannot be used as an MBSFN sub-frames.

This time segregation is one of the greatest challenges when scheduling resources for in-band RNs at the DeNB because the data can only be sent inside a limited number of MBSFN sub-frames.

In the out-band relay case, the isolation between backhaul and access links is already achieved by definition in the frequency domain. Thus, no time constraint is imposed to the backhaul link scheduling. Nevertheless, from an operator point-of-view the allocation of a separate carrier for RN access link might not always be possible due to limited spectrum or high cost involved in spectrum licensing and to the inefficiency in allocating R-UEs only in this frequency band.

Fortunately, LTE-A also standardized the usage of Carrier Aggregation (CA). CA is one of the major innovations targeting the enhancement of the peak performance in LTE-A. It consists of enabling the user's service in up to five carriers simultaneously. A single carrier is used as the Primary Component Carrier (PCC) which is always active and is responsible to carry out all the control procedures. Whereas the other carriers, the so-called Secondary Component Carriers (SCCs), are activated on demand to increase the UE's performance.

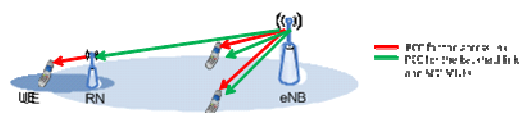

Figure 2: Carrier aggregation for out-band relay deployments.

It turns out that carrier aggregation offers an attractive solution for out-band relay deployment by allowing the carrier used for the backhaul link to be reused by the direct link at the DeNB. In

**Figure 2**, we show a scenario where two component carriers (CC) are configured. While the macro-attached user equipments (M-UEs) have their maximum achievable capacity enhanced by the introduction of a SCC, the R-UEs and the RNs use distinct CCs as their PCC.

As we have already mentioned, the scheduling, in a LTE-A REN, is done in a distributed fashion. However, the DeNB has to provide enough data to the relay node such that the system fairness and possible QoS requirements are maintained. Hence, in parallel to the M-UEs resource allocation, other issues must also be considered in the design of a relaying system:

- Number of MBSFN frames to be placed in each radio frame for the in-band relays.
- Resource partitioning between backhaul and access link.
- Multiplexing of bearers with possibly different QCI in each backhaul portion at the DeNB.
- For delay-constrained bearers: split of delay budget between backhaul and access link.

In the remainder of this paper we will give an insight on the above issues.

### Resource Partitioning Principles

A simple resource allocation strategy is to partition the resources at the DeNB by considering the number of macro users and relay attached users to estimate the fraction of resources that can be assigned to the backhaul link: the fair share of resources for the backhaul link is given as:

$$\varepsilon = \frac{N_R}{N_R + N_M} \cdot \delta,$$

where  $N_R$  is the number of relay-attached UEs in the above equation, while  $N_M$  is the number of macro UEs which are always served directly by the DeNB.  $\delta$  is a factor that scales  $\varepsilon$  depending on the total number of resources available:

- For in-band relay case, [3][4], given a certain fixed number  $P$  of MBSFN frames in a period of  $N_F$  consecutive sub-frames  $\delta = \frac{N_F}{P}$ .

- For the out-band relay, [4][5],  $\delta$  is the ratio between number of carries that can transport the backhaul link and the total number of carries used at the DeNB.

A second resource partition algorithm is the so called Fair-Throughput (Fair-TP) strategy which allows for dynamic partitioning: For a fixed number of MBSFN sub-frames, the algorithm computes the aggregate average throughput  $\Phi_B$  on the backhaul link and  $\Phi_M$  on the access link to all macro UEs. Within the non-MBSFN frames it is expected that  $\Phi_M$  increases, while the macro users are scheduled, and that  $\Phi_B$  decreases. The idea behind this strategy is to allocate resource to the backhaul link until

$$\frac{N_R}{\Phi_B} < \frac{N_M}{\Phi_M},$$

i.e., as long as the backhaul link is lagging behind we allocate resources to the RN, and only when the above condition is satisfied the macro UEs are allocated.

While in in-band relay scenarios the prioritization of the backhaul link is reasonable due to the few transmission opportunities, this approach might not be required when using out-band RNs due to the carrier separation. Hence, in this scenario the resource allocation can be simplified by including the backhaul link in the regular Proportional-Fair scheduling process, the so-called ExtPropFair strategy. In this case, the RN is viewed as a super user from the perspective of the scheduler. In order to account for the fact that all the subordinate R-UEs are multiplexed into their serving RN backhaul link the usual Prop-Fair metric is scaled with the number of attached R-UEs.

From the presented strategies, we can notice that although the Fair-RU strategy is simple and low complexity algorithm it does not consider the channel state of the backhaul link and might lead to under or overcompensation of the backhaul link. Thus, the Fair-TP has the advantage of partially considering the channel conditions. The obvious advantages of ExtPropFair are less

complexity and simple integration of backhaul and access link quality in the overall decision process.

### QoS-aware Scheduling for Relay Enhanced Networks

The introduction of the second hop in a relay enhanced network (REN) introduces new challenges for the support of QoS-aware services. In such networks, resource allocation on the downlink direction for the R-UEs is performed in two stages: In the first stage, while serving the macro eNB-attached UEs (M-UEs), the DeNB transfers the user data to the RN by allocating resources to the RN backhaul link. Afterwards, each RN schedules the previously received data to their subordinates R-UEs. In other words, a packet destined to a R-UE has to undergo two scheduling processes. In order to ensure that all QoS requirements hold across both radio links, we must have

$$T_{DeNB-RN} + T_{RN-UE} \leq D_{Profile}$$

$$\frac{B_{UE}}{T_{DeNB-RN} + T_{RN-UE}} \geq GBR_{QoS}$$

where  $T_{DeNB-RN}$  is time between the arrival of the packet at the DeNB until it is received at the RN,  $T_{RN-UE}$  is the interval between the packet reception in the RN and the time the packet is received at the R-UE, and  $D_{Profile}$  is the delay requirement of the corresponding flow. Moreover,  $B_{UE}$  is the volume of data transferred in the time interval  $T_{DeNB-UE} + T_{RN-UE}$  and  $GBR_{QoS}$  is the rate requirement of the used QoS profile.

To this end the schedulers have to serve the UEs in a way that these requirements are not violated. Thus, in NOMOR's simulator we have proposed the scheduler to support a QoS-aware metric, [4][6], defined as:

$$m_{QoS}(n, t) = \left( \frac{GBR(n)}{R(n, t)} \right)^\sigma \frac{\omega_d(n, t)}{P(n)}$$

where  $R(n, t)$  is the average throughput of the flow  $n$ ,  $P(n)$  is the priority of the flow  $n$  and  $\sigma$  is a scalar factor used to emphasize the influence of the rate ratio in  $m_{QoS}$ .  $\omega_d(n, t)$  is the delay

coefficient and is defined as:

$$\omega_d(n, t) = \exp\left(\beta \frac{d_{HOL}(n, t)}{D_{Profile}(n)}\right)$$

where  $d_{HOL}(n, t)$  is the head of line (HOL) delay of the flow  $n$  at time  $t$ ,  $D_{Profile}$  is the delay requirement of the flow  $n$  defined by its QoS profile, and  $\beta$  is a scalar factor used to enhance the effect of the exponential.

However, in a REN the definition of the scheduling metric is just part of the entire process. In order to assure that QoS requirements are fulfilled for the R-UEs, we also have to take care that the data reaches the RN on time. Hence, multiplexing of the backhaul link is a key issue. A simple way to realize that is to consider at the DeNB, from a scheduling perspective, the backhaul link as a normal link, with the QoS requirements of all underlying flows merged into single "super flow" for each QCI: for each distinct QoS type used by the R-UEs we create a super flow with an aggregate rate requirement corresponding to the sum of all sub-flows ( $n$ ) belonging to this flow type.

$$R_B \geq \sum R_n$$

Furthermore, the delay requirement for the created "super flow" is defined as

$$D_{QoS-DeNB} = \frac{D_{profile}}{2},$$

This latter equation enforces the maximum allowed delay in each of the two scheduling round to be halved. This forces the scheduler to send the packet before what it normally would offer the second scheduler the possibility of delivering the data before the packet deadline.

### NOMOR's LTE-A Simulation Capabilities

In this section, we introduce NOMOR's LTE-A simulator capabilities with regard to relay operation. Figure 3 depicts the architecture of the LTE-Advanced relay testbed developed by NOMOR within the scope of the EU funded ARTIST4G research project. We note that the testbed is composed of the following nodes: NCE, eNB, UE, MME, Gateway, and RNs.

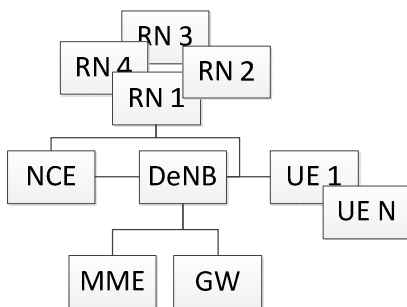

Figure 3: LTE-A testbed block diagram with RNs

#### A. Testbed nodes

The NOMOR Channel Emulator (NCE) is the responsible for emulating the physical conditions of the radio links. Among other functionalities it is responsible for:

- Configuration of the physical channel depending on the antenna pattern, cell layout, transmission power, etc.;
- Generation of the channel state information such as RSRP and SINR;
- Decoding of the allocation information from the eNB/RN to generate interference information;
- Estimation of BLER.

The NCE has been tested and is fully compliant with the 3GPP channel model requirements.

The NOMOR eNB is a full protocol stack implementation developed under C++ environment as a multi-layered and multi-threaded application. It consists of the L2 protocol stack (i.e. the PDCP, RLC, and MAC layer), the L3 radio resource control (i.e. the RRC layer), the L3 S1-Application Protocol (i.e. S1AP-Layer), the L3 X2-Application Protocol (i.e. X2AP-Layer), the user-plane interface to the EPC (i.e. the S1-U interface), and the OAM module providing some basic OAM functionality and also coupling possibility with an external OAM module.

The NOMOR's UE emulator is implemented in a similar way as the eNB and contains the counterpart of the eNB radio interfaces.

The NOMOR MME emulator and the NOMOR S-/P-GW are implemented using C++ as a monolithic and multi-layered application. The MME also includes other system facilities for

ASN.1 encoding, UDP and IP connectivity, timing, tracing, configuration etc. The gateways are responsible for terminating the connection between the eNB or UE to the core network.

#### B. Relay implementation

NOMOR's relay node implementation is a mix of the NOMOR's eNB protocol and the NOMOR's UE emulator. The current relay implementation supports the following main functions:

- UEs (M-UEs) can attach directly to DeNB or to the RNs;
- The RN appears as a UE to DeNB and as an eNB to its UEs (R-UEs) ;
- Necessary MBSFN sub-frame modifications for MAC operation;
- The RNs have their own cell ids;
- In-band mode of operation via MBSFN sub-frames;
- Out-band mode of operation via carrier aggregation functionalities;
- Proportional Fair scheduling for UEs attached to an eNB/RN
- Different types of partitioning of resources between RNs and UEs
- R-PDCCH allocation when there are R-UEs present

#### C. Scheduler implementation

Our QoS scheduler is composed of two main parts. The main function of the so-called Time Domain (TD) scheduler is to create a candidate list of users that will be scheduled in this scheduling round. First, the users are sorted according to their QoS-metric. For sake of complexity, the TD scheduler limits the number of users that will be forwarded to the next phase. The list is then forwarded to the Frequency Domain (FD) scheduler which is responsible for the allocation of the frequency resource units to the users in the candidate list: all the resources are visited one by one and the user with the best metric is allocated the particular resource unit. After the allocation of each resource unit, the average throughput of the allocated user is updated and the allocation

process is repeated for the other resource units until all resources have been allocated or no data is available on the transmitting buffers.

#### D. Traffic generator

NOMOR's traffic generator is an IP-based traffic creator that can be configured to work in various modes for example:

- Full-buffer in which the traffic generator constantly checks for the buffer levels and it always keeps them above a pre-configured threshold;
- Constant Bit-rate (CBR) mode in which the traffic generator creates packets deterministically in intervals which depend on the bitrate configured for each traffic.

For simplicity the NOMOR's traffic generator is implemented in the PDCP layer of the DeNB protocol stack.

### Key Simulation Results

#### A. Deployment Scenario

The performance evaluation of the proposed strategies is conducted using protocol level simulations, i.e. all the procedures are standard compliant. Nevertheless, the radio links are emulated by modelling the physical channel. The used channel model complies with the 3GPP Case 1 for urban macro cells with an ISD of 500m, as specified in [7].

Our deployment scenario consists of a single macro cell with 1 DeNB and 2 RNs attached to it. Within the macro cell, a so-called "hot-spot" scenario is assumed: 25 UEs are placed such that a pair of 2 UEs (the R-UEs) always ends up in the coverage region of each RN and the remaining 21 UEs (the M-UEs) in the coverage region of the DeNB. In addition, all UEs are periodically relocated randomly within their respective coverage regions.

In the case of out-band relaying two 5 MHz carriers will be used for this evaluation while in the case of in-band relaying a single 10 MHz carrier is deployed.

#### B. Traffic Model

For the resource partition simulations no explicit

QoS requirements are defined. Hence, we have used a full buffer traffic generated.

For the QoS simulations two main traffic types were defined:

- VoIP traffic: emulated using a CBR traffic generator of 128 kbps. In order to emulate real QoS conditions, this type of traffic has a maximum end-to-end of 100 ms and the service priority is defined as 2 in the scheduler [7];
- Video streaming traffic: emulated as a 256 kbps CBR service with a maximum packet end-to-end delay of 300 ms and the service priority of 5.

#### C. Performance Analysis

##### a) Resource partition

Figure 4 contains the resource partition results for out-band relaying compared to DeNB-only with carrier aggregation, i.e., the case where no RN is active and all 25 UEs are connected directly to the DeNB. As can be observed, for the given deployment scenario with 2 RNs, a significant performance gain is possible over the whole range of throughput values with any of the proposed resource allocation strategies. Nevertheless, Ext-Prop-Fair seems to be the preferred solution due to its unified framework and best performance in the low and medium range.

When comparing in-band relaying to DeNB-only without carrier aggregation, we also observe a similar relative gain in Figure 5. However, from a system perspective, the preferred strategy is not that obvious: While Fair-RU achieves better performance across all UEs, we have noticed during our simulations that due to over-compensation of backhaul link, it penalizes the M-UEs, making the Fair-TP scheme more attractive.

In general outband backhaul using carrier aggregation at the Donor eNB outperforms inband signalling, partly due to better link adaptation in two carriers. Nevertheless it should be noted that the PDCCH overhead required to enable parallel scheduling in two carriers or cross carrier scheduling has not been considered in the simulation.

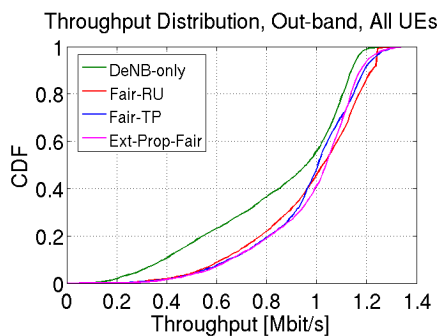

Figure 4: Out-band case: Throughput CDF of the all UEs for different strategies vs. DeNB only case.

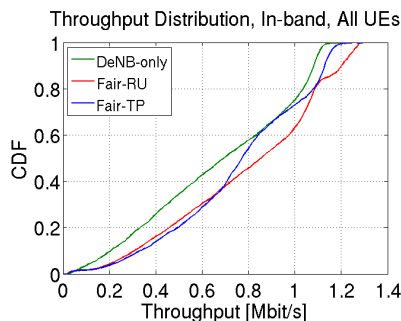

Figure 5: In-band case: Throughput CDF of the all UEs for different strategies vs. DeNB only case.

#### b) QoS provisioning

In this sub-section, we present some simulation results with regard to QoS provisioning in relay enhanced networks using an inband backhaul link. To this end, we consider a traffic mix of voice and streaming users with distinct QoS requirements as defined earlier.

In Figure 6 and Figure 7, we present the achieved throughput and delay CDFs for these services respectively for the conventional (static resource partitioning) scheme and the proposed

QoS-aware scheduling scheme.

We observe that for conventional scheme in Figure 6, especially the M-UEs fail to achieve their QoS requirements. The throughput CDF in Figure 6 (a) shows that 5%-ile throughput values of VoIP and video M-UEs are 89.5 kbps and 102.5 kbps compared to the traffic bit rates of 128 kbps and 256 kbps respectively. Furthermore, in the delay CDF in Figure 6 (b), we observe the 95%-ile delays for the two traffic types to be 133 ms and 373 ms compared to the maximum allowed latency of 100 ms and 300 ms.

With the proposed QoS-aware resource allocation scheme, the QoS satisfaction of all users improve, as can be seen in Figure 7. We observe that 5%-ile throughput values of VoIP and video M-UEs increase to 126.5 kbps and 194.5 kbps, while the corresponding 95%-ile packet delays reduce to 87 ms and 297 ms respectively. Significant overall gain is observed, since backhaul resources are assigned dynamically based on RN-UE's QoS constraints instead of a fixed assignment based on the number of RN-UEs only.

In order to summarize the effectiveness of the proposed QoS-aware resource allocation scheme for relay enhanced networks, we present in Table 1 a comparison with the conventional scheme, in terms of the fraction of satisfied users. It can be seen that especially for M-UEs, the fraction of satisfied users is appreciably increased by employing the proposed QoS-aware resource allocation scheme. For instance, the number of satisfied video UEs increases from 8.1% to 88.8% w.r.t. the achieved throughput and from 74.7% to 95.3% w.r.t. the experienced packet delay.

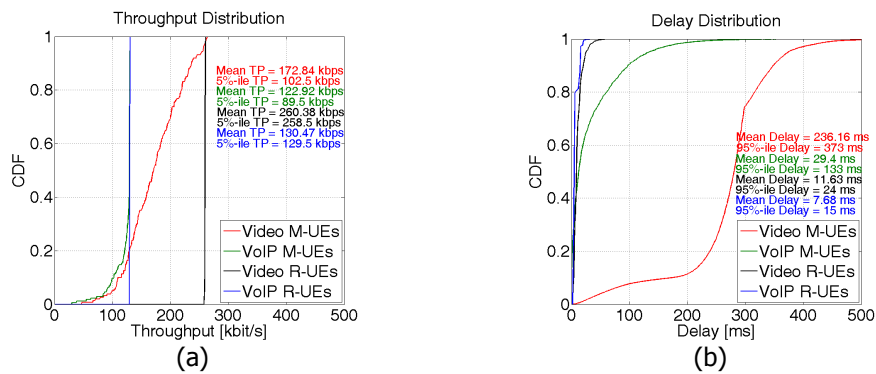

Figure 6 DeNB+2RN scenario with conventional resource allocation (static resource partition plus proportional fair scheduler): Throughput and Delay CDF comparison for different UE groups (M-UEs and R-UEs) and traffic type (VoIP and Video).

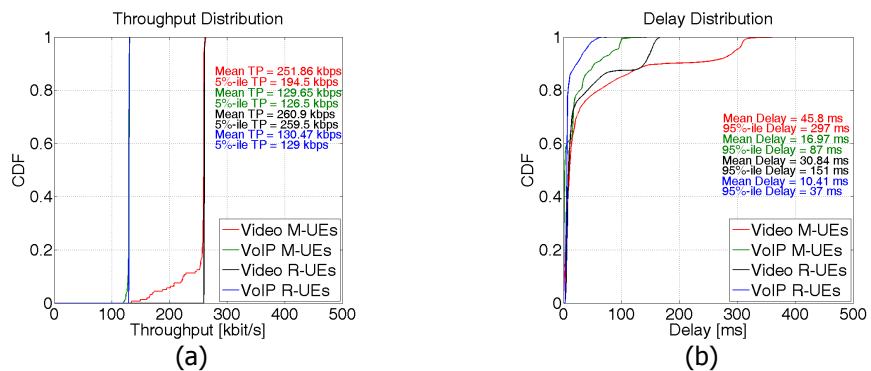

Figure 7 DeNB+2RN scenario with proposed QoS-aware resource allocation: Throughput and Delay CDF comparison for different UE groups (M-UEs and R-UEs) and traffic type (VoIP and Video).

### Conclusions

In this white paper, we considered the problem of resource allocation in relay enhanced networks. First, we addressed the fundamental question of how to split the resources at DeNB between the macro-access and the backhaul link. Next, we proposed and demonstrated mechanisms to provide QoS support to users in relay enhanced networks, highlighting the various additional challenges that must be considered in relaying scenarios. Furthermore, we throw some light on the capabilities of the NOMOR's LTE-A simulator

which is a powerful tool for simulating relay related issues and is based on a 3GPP compliant channel model. Some representative results obtained from this simulator have been included in this white paper. In summary, outband transmission to the relay nodes in combination with carrier aggregation proved to be very efficient. For resource partitioning, we observed that Fair-TP and ExtPropFair schemes manage to achieve a good balance between throughput gain and effect on the direct users however the latter involves less changes into the



existing scheduler. On the other hand, for QoS provisioning, we demonstrated that our novel QoS-aware resource allocation proposal brings appreciable gains in terms of backhaul resource usage and user satisfaction.

Table 1. DeNB+2RN scenario: Fraction of satisfied users for the proposed QoS-aware (Prop.) vs. the conventional static resource partitioning based (Conv.) resource allocation

UE Type	Fraction of satisfied users w.r.t			
	achieved throughput		experienced delay	
	Conv.	Prop.	Conv.	Prop.
Video M-UES	8.1%	88.8%	74.7%	95.3%
VoIP M-UES	80.0%	99.4%	90.5%	99.0%
Video R-UES	100%	100%	100%	100%
VoIP R-UES	100%	100%	100%	100%

## References

- [1] REPORT ITU-R M.2134 - Requirements related to technical performance for IMT-Advanced radio interface(s).
- [2] 3GPP TR 36.912 V9.1.0 (2009-12), Feasibility study for Further Advancements for E-UTRA (LTE-Advanced).
- [3] G. Liebl, T. M. de Moraes, A. Soysal, and E. Seidel, "Fair Resource Allocation for Inband Relaying in LTE-Advanced," in 2011 8th International Workshop on Multi-Carrier Systems & Solutions (MC-SS), Herrsching, Germany, May 2011.
- [4] T. Martins de Moraes, M. D. Nisar, A. Gonzalez, and E. Seidel, "Resource Allocation in Relay Enhanced LTE Networks", in EURASIP Journal on Wireless Communications and Networking, 2012 (Submitted)
- [5] G. Liebl, T. Martins de Moraes, A. Gonzalez, A. Soysal, and E. Seidel, "Fair Resource Allocation for the Relay Backhaul Link in LTE-Advanced," in IEEE Wireless Communications and Networking Conference (WCNC 2012), Paris, France, Apr 2012.
- [6] T. Martins de Moraes, A. Gonzalez, M. D. Nisar, and E. Seidel, "QoS-aware Resource Allocation for In-band Relaying in LTE-Advanced," in Eighth International Conference on Wireless and Mobile Communications (ICWMC 2012), Venice, Italy, Jun 2012.
- [7] 3GPP TR 36.814 V9.0.0 (2010-03), "Technical Specification Group Radio Access Network; Evolved Universal Terrestrial Radio Access (E-UTRA); Further advancements for E-UTRA physical layer aspects, (Release 9)," Technical Report 3GPP, 2010.

*Note: This white paper is provided to you by Nomor Research GmbH. Similar documents can be obtained from [www.nomor.de](http://www.nomor.de). Feel free to forward this issue in electronic format. Please contact us in case you are interested in collaboration on related subjects.*

### System Level Simulation Services

Nomor Research has developed a comprehensive simulation environment supporting various standards such as LTE, LTE Advanced and HSPA and offers related services to support research, development and standardisation.

The simulator can be used on project basis or in customized simulation campaigns. The performance of the system level simulator has been calibrated to simulation results obtained in standardisation.

Features of the dynamic multi-cell, multi-user system level simulator include:

- macro-cell and HetNet deployments (pico-, femto-cell, relay nodes)
- flexible base station and user configurations and drop models
- different transmitter and receiver chains incl. MIMO, ZF, MMSE
- channel modeling with slow/fast fading, pathloss, full user mobility
- intra- and intercell interference modeling for OFDMA, SC-FDMA and WCDMA
- 2D and 3D antenna pattern and multi-antenna beam forming
- Extensive metrics and KPIs: capacity, throughput, spectral efficiency, user QoS etc

Research on advanced algorithms include, but are not limited to:

- advanced features as link adaptation, HARQ, power control, measurements
- scheduling and resource allocation algorithms considering channel and buffer status, QoS etc.
- inter-cell interference coordination, avoidance and cancellation
- Single user-, multi-user MIMO with open and closed loop feedback
- Cooperative multi-point transmission and reception
- functions for self-organising and self-optimizing networks (e.g. load balancing, mobility optimization, tilt optimisation, range extension, power saving etc.)



If you are interested in our services please contact us at [info@nomor.de](mailto:info@nomor.de) or visit us at <http://www.nomor-research.com/simulation>